



# SOCIAL DISTANCING BARRIER

- Solution for physical distancing
- Short or long term installation
- Ideal for factories, warehouses and workshops
- Ultra-stable and safe
- Lightweight anodized aluminum structure
- Recycled rubber counterweight bases
- Easy to clean and scratch resistant
- Fire and UV resistant PVC panel



Prevents  
COVID-19



Installed in  
10 min



Made in  
Canada

# OVERVIEW

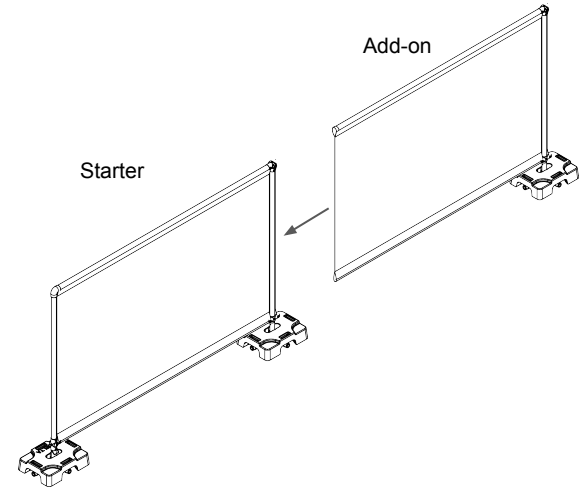

Delta Prevention's social distancing barrier keep workers at a safe distance and reduce the spread of the virus between workstations.

Easy to assemble, heavy-duty and modular, they create a physical barrier while allowing the passage of light and communication.

# APPLICATIONS



Machine operators



Shipping and receiving

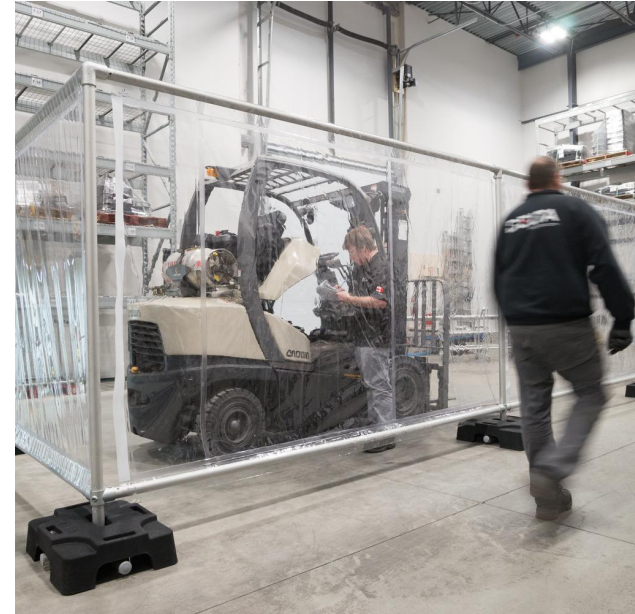

Fleet maintenance

# FEATURES



The add-on allows you to create longer walls



Corner clamps  
*(optional)*



Velcro connection for maximum sealing  
*(optional)*

# DIMENSIONS

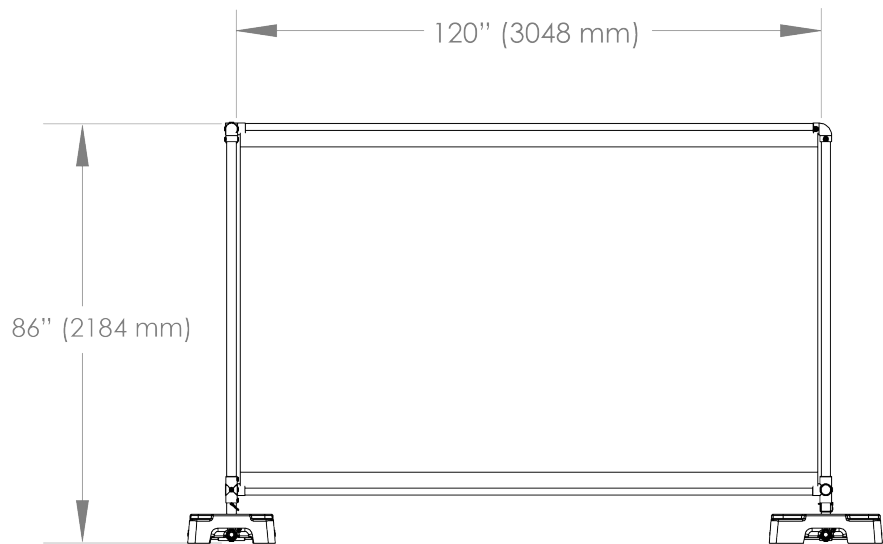

Starter

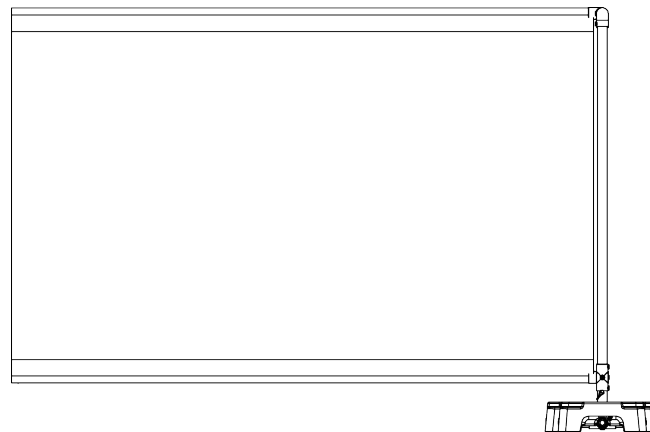
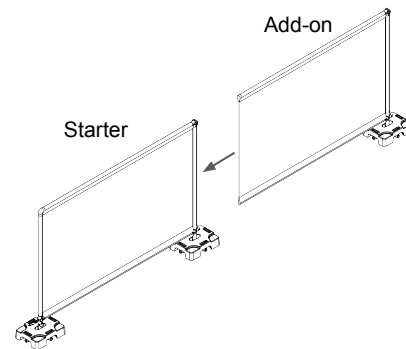

Add-on

# TECHNICAL SPECIFICATIONS

Total length *	120" (3048 mm)	Material - frame	Anodized aluminum 6061-T6	Wall panels - FR rating	Yes, MVS #302, NFPA 701
Height *	86" (2184 mm)	Material - bases	100% recycled rubber	Made in	Canada
Width *	18" (457 mm)	Material - clamps	Galvanized steel		
Tubing diameter (outside)	1,9" (482mm)	Wall panels	PVC 20 ga (0,2 mm)		
Total weight *	172 lbs	Wall panels - UV rating	0,4 phr, ASTM G154		

\* Starter section

## PACKAGING



### Starter:

1 x skid, 48" x 42" x 20", Weight: 160 lbs  
 1 x bundle, 120" x 4" x 4", Weight: 40 lbs

### Add-on:

1 x skid 48" x 42" x 12", Weight: 100 lbs  
 1 x bundle, 120" x 4" x 4", Weight: 30 lbs